

Installation manual
Presto LED

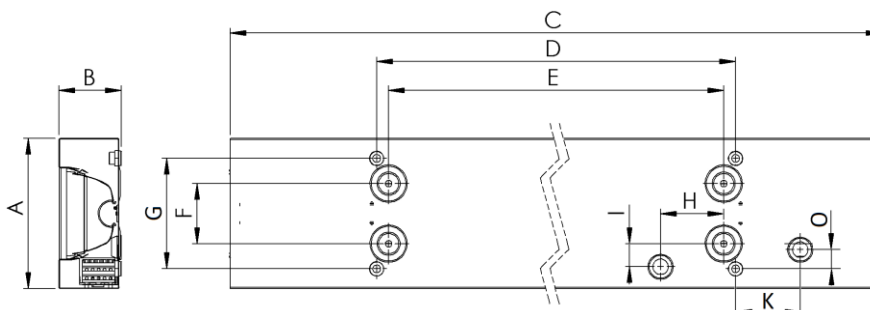

220-240V/50-60Hz

1. Dimensions and mounting holes

Model	A [mm]	B [mm]	C [mm]	D [mm]	E [mm]	F [mm]	G [mm]	H [mm]	I [mm]	K [mm]	O [mm]	Weight [kg]
1145 DI	125	52	1145	900	880	50	92	80	18			2,0
1145 DI-IN	125	58	1145	900			92			16	18	2,45
1435 DI	125	52	1435	1190	1150	50	92	80	18			2,5
1435 DI-IN	125	58	1435	1190			92			16	18	3,0

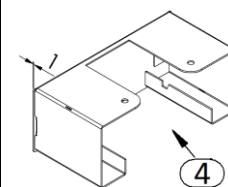

2. Installation

a) carefully remove the luminaire from the package and put in on a stable surface

b) using gloves gently remove louver from the casing

c) PENDANT INSTALLATION screw on simple suspension and mechanical suspension to the ceiling in the spacing D and G. Fix 4 line regulators into montage bushes on the back of the luminaire. Slightly loosen outside regulator nut, slip the line to reach desired suspension length, then tighten on the nut again. Pulling the wire deeper causes lifting the luminaire up, to lower it – loosen the nut and press it towards the luminaire – the line will come out.

SURFACE INSTALLATION place nail anchors in the ceiling according to E x F spacing, put the luminaire on

d) place the end caps nr. 4 on the ends of luminaire, pull the blocking element nr. 2, then tighten the screws nr. 3.

e) connect the power supply according to marking on the power connector

f) put the connector of the PE wire on the louver

f) put the louver back on

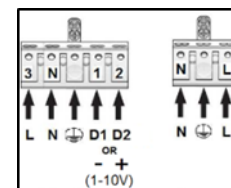
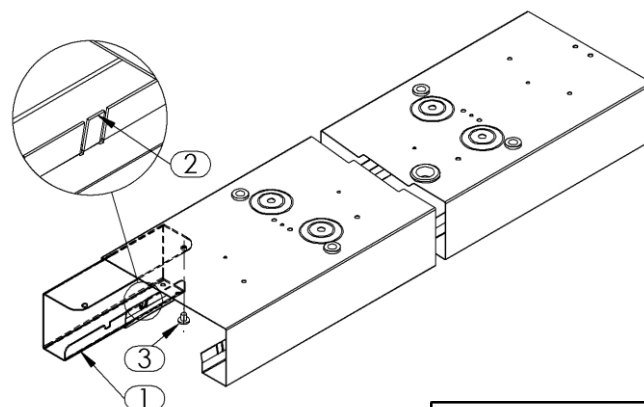

Light line installation:

Light line assembly is done by sliding the joining kit nr1 in, tilt back the blocking element nr.2 and adjusting screw nr3.

Next, slide the other luminaire onto the other ends of joining kit and tighten the screws. Connect the plugs or through-wiring together and connect one of the fittings to the power accordingly to the markings on the connection terminal and the drawing above.



3. Important warnings:

- Luminaires may be installed by qualified and registered personnel only.
- Any manipulation inside the luminaires when the power is activated causes the risk of electrical shock
- The manufacturer is not responsible for any flaws resulting from non-compliance with these instructions
- The manufacturer reserves the right to change the construction of the luminaire
- Do not install the luminaire in places without sufficient air circulation
- To guarantee safe luminaire functioning, please follow the installation instructions



The European Directive 2002/96/EC on waste electrical and electronic equipment, requires that electric and electronic devices must not be disposed of in the normal household waste. The crossed out wheeled bin is reproduced in order to remind obligations towards separate collection. For correct disposal, please use authorized waste disposal facilities or return to the distributor at the date a new lighting fitting is purchased. Lamps, if disposed together with the lighting fitting, shall not be broken up since they contain substances which are highly polluting to the environment. Unauthorized disposal of the foregoing waste material is punishable by law.

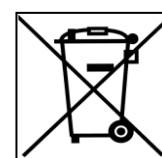

INSTALLATION MANUAL



PRESTO OPAL /MPRM LED

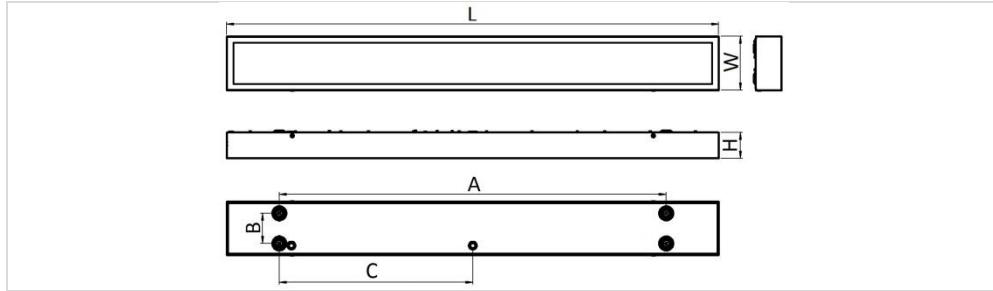

220-240V / 50-60Hz

POWER (W)	L (mm)	W (mm)	H (mm)	A (mm)	B (mm)	C (mm)	Weight (kg)
31 DI	1145	126	60	900	70	450	3,5
37 DI	1435	126	60	900	70	450	4
43 DI-IN	1145	126	68	960	70	15	4
52 DI-IN	1435	126	68	1200	70	15	4,5

Light source in the fitting cannot be switched or replaced by anyone but manufacturer, his service representative or similarly qualified personnel.

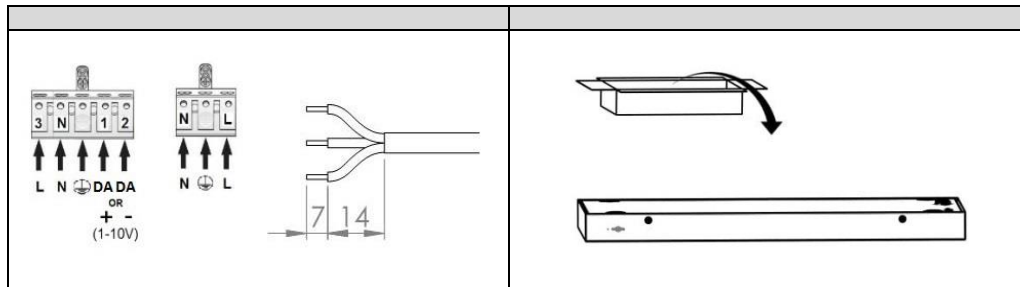

Important warnings:
 The luminaires may be installed by qualified registered personnel only.
 Any manipulation inside the luminaire when the power is activated causes the risk of electric shock.
 The manufacturer is not responsible for any flaws resulting from non-compliance with these instructions.
 The manufacturer reserves the right to change the construction of the product.
 Do not install the luminaire in places without sufficient air circulation.
 To guarantee safe luminaire functioning, please follow the instructions in the installation instructions.
 PXF Lighting website: www.pxf.pl

The European Directive 2002/96/EC on waste electrical and electronic equipment, requires that electric and electronic devices must be disposed of in the normal household waste. The crossed out wheeled bin is reproduced in order to remind obligations towards separate collection. For correct disposal, please use authorized waste disposal facilities or return to the distributor at the date a new lighting fitting is purchased. Lamps, if disposed together with the lighting fitting, shall not be broken up since they contain substances which are highly polluting to the environment. Unauthorized disposal of the foregoing waste material is punishable by law.

